



159th NYYC ANNUAL REGATTA

Presented by ROLEX

June 14-16, 2013
Newport, Rhode Island



SAILING INSTRUCTIONS

1 RULES

- 1.1 The regatta will be governed by the rules as defined in *The Racing Rules of Sailing* (RRS). Appendix D, Team Racing Rules, will not apply for the Rolex Cup or Great Corinthian Trophy team events.
- 1.2 The Annual Regatta website can be found at <http://nyyc.org/yachting/racing/159th-annual-regatta>.
- 1.3 **Offshore Special Regulations:** At minimum, all yachts shall comply with the 2012-2013 ISAF Offshore Special Regulations (OSR), Category 5 posted as NOR Addendum 1 on the Annual Regatta website and shall comply with their class rules, where applicable. In the event of a conflict between these regulations and applicable class rules, the class rules shall apply.
 - a) Yachts that are not normally rigged with lifelines are exempt from Regulation 3.14.
 - b) All competitors, and in particular the person in charge, shall be fully aware of and understand the responsibilities described in OSR 1.02 and RRS 4:

1.02 Responsibility of Person in Charge

1.02.1 The safety of a yacht and her crew is the sole and inescapable responsibility of the person in charge who must do his best to ensure that the yacht is fully found, thoroughly seaworthy and manned by an experienced crew who have undergone appropriate training and are physically fit to face bad weather. He must be satisfied as to the soundness of hull, spars, rigging, sails and all gear. He must ensure that all safety equipment is properly maintained and stowed and that the crew know where it is kept and how it is to be used.

ADD: He shall also nominate a person to take over the responsibilities of the Person in Charge in the event of his incapacitation.

1.02.2 Neither the establishment of these Special Regulations, their use by race organizers, nor the inspection of a yacht under these Special Regulations in any way limits or reduces the complete and unlimited responsibility of the person in charge.

1.02.3 Decision to race -The responsibility for a yacht's decision to participate in a race or to continue racing is hers alone - RRS Fundamental Rule 4.

- 1.4 The US SAILING Prescriptions to the RRS that are posted as NOR Addendum 2 on the Annual Regatta website shall apply.
- 1.5 The Protest Committee may impose suitable penalties, other than disqualification, for violations of the ISAF Offshore Special Regulations or other non-Part 2 rules. This changes RRS 64.1.
- 1.6 The 2013 IRC Rules and Regulations shall apply to yachts racing under IRC.
- 1.7 The 2013 PHRF-NB Regulations shall apply to yachts racing under PHRF.
- 1.8 Farr 40 Class – Special sailing instructions are posted as SI Appendix E – Farr 40 Class and apply to racing on Thursday and Friday, June 13-14, as part of the Farr 40 USA Circuit Event #4. SI Appendix E1, E7.2, E15.1 and E19 also change these Annual Regatta sailing instructions as they apply to the Farr 40 Class.
- 1.9 RED Fleet – Special sailing instructions for racing in the Red Fleet are posted as SI Appendix D – Red Fleet.

- 1.10 The current class rules shall apply to all yachts racing as a one-design class, except as noted in these sailing instructions.
- 1.11 Swan 42 Class – For any Swan 42 electing to sail in the Swan 42 class in the Around-the-Island Race on Friday, June 14, the following will apply:
 - a) Yachts that comply with the Swan 42 Class One-Design rules will be scored as a one-design class.
 - b) Any Swan 42 that, when sailing in Class one-design configuration, has a valid IRC certificate, will also be “double-scored” in the overall IRC fleet and is eligible for the overall IRC award.
 - c) A Swan 42 that has a valid IRC certificate, but does not comply with the Swan 42 Class One-Design rules, shall be placed in an IRC class.
- 1.12 The following documents (found on the Class website at <http://www.12mrclass.com/>) shall apply to the 12 Metre Class only:
 - a) The International Twelve Metre Association (ITMA) By-laws and Regulations as of July 8, 2008 and updated November 11, 2011;
 - b) The International Twelve Metre Class Rule approved July 17, 2011;
 - c) Amendment E – Table 1 to the Class Rules revised March 9, 2012.

2 ENTRIES

- 2.1 Eligible yachts shall enter by completing online registration with the Organizing Authority on the Annual Regatta website. Eligibility requirements for yachts and method of entry are detailed in the Notice of Race.
- 2.2 Team entries for the Rolex Cup and the Great Corinthian Trophy shall be entered on the separate entry forms posted on the Annual Regatta website. There is no entry fee for either team event.

3 NOTICES, COMPETITOR INFORMATION AND SIGNALS MADE ASHORE

- 3.1 Notices, including race results, amendments and protest hearing schedules, shall be posted on the Official Notice Board located in the courtyard of the NYYC Sailing Center at Harbour Court. This information may also be posted on the Annual Regatta website.
- 3.2 Flag signals will be flown from the flagpole at Harbour Court.
- 3.3 Any change to the sailing instructions will be posted before 0900 on the day it will take effect, except that any change to the schedule of races will be posted by 2000 on the day before it will take effect. Flag “Lima” will be flown to signify such posting.
- 3.4 When Pennant “AP” is displayed ashore, “one minute” is replaced with “not less than one hour” in Race Signal “AP”.
- 3.5 Signals designating the rendezvous locations will be displayed at 0900 on Friday, Saturday and Sunday from the flagpole at Harbour Court. The Race Committee will endeavor to announce the locations as described in SI 6 at that time over VHF Channel 72. The failure to make this announcement or for a yacht to hear this announcement will not be grounds for redress. This changes rule 62.1(a).
- 3.6 After the rendezvous locations and any other regatta announcements have been made, Race Committee Signal Boats will monitor and communicate with their respective fleets on the VHF channels published in SI 4.3.

4 CLASSES AND IDENTIFICATION

- 4.1 The Organizing Authority will divide yachts into classes.
 - a) For the Farr 40 Class racing on Thursday and Friday, June 13-14, the fleet is designated the BLUE fleet.
 - b) For the Around-the-Island Race on Friday, June 14, classes will be assigned a numeral designation and be designated the WHITE fleet.
 - c) For racing on Saturday and Sunday, classes will be assigned a numeral designation and placed in one of four fleets (Blue, White, Green, Red).

4.2 **Scratch Sheets** - There will be a separate scratch sheet for the Around-the-Island Race on Friday and for each fleet (Blue, White, Green, Red) racing on Saturday and Sunday. Note that a yacht may be in different classes in the different portions of the Annual Regatta. The scratch sheets will be distributed at registration, posted on the Official Notice Board and posted on the Annual Regatta website.

4.3 **VHF Channels** - The Race Committee VHF channels for each fleet are shown below:

- | | | | |
|--------------------------|-------------|----------------|---|
| a) Thurs/Fri, June 13-14 | Blue Fleet | VHF Channel 72 | |
| b) Friday, June 14 | White Fleet | VHF Channel 69 | (All classes in Around-the-Island Race) |
| c) Sat/Sun, June 15-16 | Blue Fleet | VHF Channel 72 | |
| | White Fleet | VHF Channel 69 | |
| | Green Fleet | VHF Channel 71 | |
| | Red Fleet | VHF Channel 77 | |

4.4 **Backstay Flags** – Each yacht shall display the numeral flag corresponding to her class designation, as shown on the scratch sheet, from her backstay approximately six feet above the deck and above the Rolex flag, from the warning signal of the first class in her fleet until she is no longer racing. Yachts without a permanent backstay shall conspicuously display these flags in an alternate position in the aft part of the yacht.

4.5 **Bow Stickers and Flags** - Each yacht shall display the Rolex backstay flag and bow stickers provided at registration while racing. Wooden yachts and Classics are not required to apply the bow stickers.

5 SCHEDULE OF RACES

- 5.1 The Around-the-Island Race will be sailed on Friday, June 14, and is open to all eligible yachts. This race is separate from the any racing on Saturday and/or Sunday. Course signals will be made on Friday, June 14, at 1200. Classes may not start in numerical order. See SI 9.2 and SI Appendix A.
- 5.2 The TWO-DAY Series will be held on Saturday and Sunday, June 15-16. All races will count in the TWO-DAY Series. The course signals will be made at 1100 for all fleets on Saturday, June 15 and Sunday, June 16.
- 5.3 There will be one NAVIGATOR Race on Saturday, June 15 and one on Sunday, June 16. Each race will be scored separately. The first course signals will be at 1200 each day.
- 5.4 No warning signal shall be made after 1500 on Sunday, June 16.

6 RENDEZVOUS LOCATIONS

Fleet rendezvous locations are listed below and will be designated as described in SI 3.5. See SI Appendix F – NYYC Primary Race Areas.

Rhode Island Sound:

- Area “A” - in the vicinity of 160° for 1.2 NM from R “2” QR Whistle marking Brenton Point
- Area “B” - in the vicinity of 120° for 2.5 NM from R “2” QR Whistle marking Brenton Point
- Area “C” - in the vicinity of 225° for 2.0 NM from R “2” QR Whistle marking Brenton Point
- Area “D” - in the vicinity of 200° for 3.5 NM from R “2” QR Whistle marking Brenton Point
- Area “E” - in the vicinity of 165° for 2.5 NM from R “2” QR Whistle marking Brenton Point
- Area “F” - in the vicinity of 150° for 4.5 NM from R “2” QR Whistle marking Brenton Point

Newport Harbor and near Newport Bridge:

- Area “K” - between Goat Island and Rose Island
- Area “M” - in the vicinity of R “12” west of Rose Island
- Area “N” - off Coasters Harbor Island (just north of east end of Newport Bridge)
- Area “O” - in the vicinity of Potter Cove (just north of west end of Newport Bridge)

North of Newport Bridge:

- Area “R” - in the vicinity of 200° for 0.5 NM from Halfway Rock
- Area “T” - in the vicinity of G “7” QG off Quonset Point
- Area “V” - north of Hope I east of Prudence Island

7 CHECK-IN AND RETIREMENT

- 7.1 Prior to the warning signal for the first race each day, all yachts shall check in with the Race Committee Signal Boat by passing astern on starboard tack and announcing their sail number. The Race Committee will acknowledge by responding with the number heard.
- 7.2 Yachts retiring are requested to inform the Race Committee on their fleet VHF channel or by calling (401) 845-9633.

8 COURSES & MARKS

The courses and marks for each section of the Annual Regatta are described in the SI Appendices as shown:

Thurs/Fri, June 13-14	Farr 40 Class	SI Appendix E	Farr 40
Friday, June 14	Around-the-Island Race	SI Appendix A	All classes
Sat/Sun, June 15-16	South Bay Race Chart Courses	SI Appendix B	Green, Navigators, S Class
	Drop Mark Courses	SI Appendix C	Blue & White
	Red Fleet Drop Mark Courses	SI Appendix D	Red

9 THE START

- 9.1 Races will be started in accordance with rule 26.
- 9.2 The intended order of start for the Around-the-Island Race on Friday, June 14, will be included in the Race Committee's announcement on VHF Channel 72 at 0900. Classes may not start in numerical order. The Race Committee may combine two or more classes into one start by displaying multiple class flags at the Warning Signal. The Race Committee will endeavor to announce the next class(es) to start on VHF Channel 72.
- 9.3 A yacht starting later than 20 minutes after her starting signal will be scored Did Not Start. This changes rule A4.
- 9.4 The starting line will be between a staff displaying an orange flag on the Race Committee Signal Boat and the course side of the port-end starting mark. The Race Committee may deploy a "Keep Off" buoy(s).
- 9.5 Yachts whose warning signal has not been made shall keep clear of the starting area.
- 9.6 Sample sequence:

Friday, June 14	Sat/Sun, June 15-16		
<u>White A-T-I</u>	<u>Two-Day</u>	<u>Navigator</u>	
1200	1100	1200	Course Signals
1205	1105	1205	Warning for first class
1206	1106	1206	Preparatory for first class
1210	1110	1210	Start for first class, Warning for second class
1211	1111	1211	Preparatory for second class
1215	1115	1215	Start for second class, Warning for third class
1216	1116	1216	Preparatory for third class
1220	1120	1220	Start for third class, etc.

10 INDIVIDUAL RECALLS

The Race Committee will endeavor to hail each premature starter over their respective fleet VHF channel. Failure to make such an announcement shall not be grounds for redress. This changes rule 62.1(a).

11 THE FINISH

The finishing line is described in the SI Appendix for each section of the Annual Regatta.

12 GOVERNMENT BUOYS

Government buoys have no required side except when specified as marks of the course. Caution should be exercised for safe navigation.

13 PENALTY SYSTEM

- 13.1 If class rules specify a penalty, a yacht that may have broken a rule of Part 2 while racing may take a penalty at the time of the incident as provided in her class rules.
- 13.2 If the class rules do not specify a penalty, rule 44.1 is changed so that a yacht has the choice between penalty systems and the Two-Turns Penalty is replaced by the One-Turn Penalty. A yacht may choose either to:
- a) take a One-Turn Penalty in accordance with rule 44.2; or
 - b) take a Scoring Penalty in accordance with rule 44.3.

14 TIME LIMIT

- 14.1 The time limit to sail the course and finish is as follows:
- a) For the Around-the-Island Race courses – five hours.
 - b) For a South Bay Racing Chart course – four hours.
 - c) For a drop mark course – three hours.
 - d) For a drop mark course for the Red Fleet – 90 minutes.
- 14.2 Yachts failing to finish within 60 minutes of the first yacht in her class to sail the course and finish, or within the time limit, whichever is later, will be scored Did Not Finish (DNF) and scored points as described in SI 16.3. This changes rules 35 and A4.

15 PROTESTS AND REQUESTS FOR REDRESS

- 15.1 It is requested that yachts intending to protest report both their intention and the yacht being protested to the Race Committee on the fleet VHF channel immediately after finishing or withdrawing from the race.
- 15.2 Written protests or requests for redress shall be submitted to the Jury Secretary in the NYYC Sailing Center as soon as possible, but not later than one hour after the Race Committee Signal Boat for that fleet has docked. The time limit for filing a protest will be posted on the Official Notice Board.
- 15.3 Protest notices will be posted as soon as possible on the Official Notice Board.
- 15.4 Protest hearings will take place at the NYYC Sailing Center as soon as possible after the notices are posted. The Jury will attempt to hear protests in the order of receipt. Representatives of yachts who are parties to a hearing shall remain on call in the vicinity of the protest rooms.
- 15.5 When a yacht has been involved in an incident that may be subject to protest, it is her responsibility to check the protest notices at the end of the protest filing time to see if she is cited in a protest. Failure of any yacht to appear when called for a hearing will be considered by the Jury as grounds for proceeding under rule 63.3(b).
- 15.6 Rule 63.5 is changed by adding, “A protest involving contact may be heard by the Protest Committee even though the requirements of rule 61.1(a) and 61.3 have not been fulfilled.”
- 15.7 Breaches of SIs 4.4, 4.5, 7, 9.5 and 18.2 will not be grounds for a protest by a yacht. This changes rule 60.1(a).
- 15.8 A violation of SI 18.2 will be considered “a gross breach of a *rule*” under rule 69.1(a).
- 15.9 On the last scheduled day of racing only, a written request for reopening a hearing shall be delivered to the Jury Secretary:
- a) Within the protest time limit if the requesting party was informed of the Protest Committee’s decision on the previous day; or
 - b) No later than 30 minutes after the requesting party was informed of the Protest Committee’s decision on that day; or
 - c) If no races are held on the last scheduled day of racing, within one hour after racing has been abandoned.
- This changes rule 66.

15.10 On the last scheduled day of racing, a request for redress based on a Protest Committee decision shall be delivered in writing no later than 30 minutes after the decision was posted. This changes rule 62.2.

16 SCORING

16.1 A yacht's series score will be the total of her race scores. There will be no drop race. This changes rule A2.

16.2 One race is required to be completed to constitute a series.

16.3 Yachts that have started and fail to finish within the time limit for any reason, shall, without a hearing, be scored by the Race Committee with points equal to the number of yachts in her class that have sailed the course and finished within the time limit, plus two. This changes rule A4.1, A4.2, and A5.

16.4 Teams competing for team trophies will be scored in accordance with the Notice of Race.

17 PRIZES

Prizes will be awarded as described in the Notice of Race.

18 NOTES

18.1 Competitors are reminded that Narragansett Bay and its approaches are considered restricted channels for commercial traffic and other vessels restricted in their ability to maneuver. Competitors must comply with the government right-of-way rules when in proximity to commercial or privileged marine traffic.

18.2 In the event there is racing in Narragansett Bay, competitors should be aware of heightened security around the Navy base in Newport just to the north of the Newport Jamestown Bridge. The area to the east of a line defined by a series of white buoys marking the Newport Security Zone along the coast of the Naval Facilities from Coasters Harbor to the breakwater at the north end of Coddington Cove shall rank as an obstruction. Yachts shall not enter this area. A Navy patrol boat monitors the area and vessels navigating in the Exclusionary Zone may face action by Coast Guard and Naval authorities.

18.3 All times herein are Eastern Daylight times. Bearings are in degrees magnetic and are approximate. Distances used herein are expressed in nautical miles (when not otherwise defined) and are approximate.

18.4 Newport Tides

Day	Date	Low Tide	High Tide	Low Tide
Friday	June 14	0534	1231	1745
Saturday	June 15	0614	1316	1838
Sunday	June 16	0701	1404	1943

18.5 For further information please contact:

New York Yacht Club, Harbour Court
5 Halidon Avenue
Newport, RI 02840
Tel: 401-845-9633
Fax: 401-846-3303
Email: sailingoffice@nyyc.org
Website: www.nyyc.org/157th-annual-regatta/

SAILING INSTRUCTIONS

Appendix A – AROUND-THE-ISLAND RACE

Friday, June 14

A1 ORDER OF START

- A1.1 The intended order of start for the Around-the-Island Race on Friday, June 14, will be included in the Race Committee's announcement on VHF Channel 72 at 0900. Classes may not start in numerical order. The Race Committee may combine two or more classes into one start by displaying multiple class flags at the Warning Signal. The Race Committee will endeavor to announce the next class(es) to start on VHF Channel 72.
- A1.2 The starting mark will be an 8' ORANGE tetrahedron buoy.

A2 COURSES FOR AROUND-THE-ISLAND RACE

- A2.1 The Race Committee will use VHF channel 72 for the Around-the-Island Race on Friday, June 14.
- A2.2 The flag(s) designating the course to be sailed will be displayed at Course Signals. The Race Committee will endeavor to announce the designated courses over VHF channel 72. Failure to make such an announcement shall not be grounds for redress. This changes rule 62.1(a).
- A2.3 Special Mark "U"
- The Race Committee may add a new first mark to any course by displaying flag "U" above a Green or Red flag on a separate pole.
 - Mark "U" is to be rounded either to STARBOARD (Green flag below "U") or to PORT (Red flag below "U").
 - The bearing and distance to Mark "U" will be displayed on a whiteboard.
 - Mark "U" will be an 8' YELLOW tetrahedron buoy.

A2.4 Course "J", clockwise around Conanicut Island:

- RG "NR" Bell 650 yards SW of Beavertail Point to starboard
- The center span of the Jamestown Verrazano Bridge
- C "5" 1,250 yards NW of Conanicut Point to starboard
- R "2" Fl R 4 Sec Bell 900 yards NE of Conanicut Point to starboard
- The center span of the Newport Jamestown Bridge
- Pass to the west of R "12" off Rose Island
- Finish off Fort Adams (see SI Appendix A 2.7 below)

A2.5 Course "JR" - if Flag "R" is flown beneath Flag "J", the Around Conanicut Island race shall be sailed in the reverse direction (counter-clockwise), with the above rounding marks passed to port, finishing off Fort Adams.

- Pass to the west of R "12" off Rose Island
- The center span of the Newport Jamestown Bridge
- R "2" Fl R 4 Sec Bell 900 yards NE of Conanicut Point to port
- C "5" 1,250 yards NW of Conanicut Point to port
- The center span of the Jamestown Verrazano Bridge
- RG "NR" Bell 650 yards SW of Beavertail Point to port
- Finish off Fort Adams (see SI Appendix A 2.7 below)

- A2.6 For the purposes of rule 32.2(c), the center spans of the Jamestown Verrazano Bridge and the Newport Jamestown Bridge shall be considered gates.
- A2.7 The finishing line for the Around-the-Island Race Courses will be between a staff displaying an orange flag on a Race Committee Boat and the finishing mark, which will be an 8' YELLOW tetrahedron buoy. The finishing line will be located approximately 0.25 NM north of the Fl R 6 sec Horn "2" on the northern point of Fort Adams.
- A2.8 In fog at the finish, the Race Committee Boat may ring a bell rapidly, for approximately 5 seconds, at intervals. The same Race Committee Boat may or may not start and finish each race.

SAILING INSTRUCTIONS

Appendix B – SOUTH BAY RACE CHART COURSES

Saturday-Sunday, June 15-16

The Green and Navigator Fleets, including 12M, Classics, 6M, and the Navigator Race classes (PHRF, IRC NS) will race on course(s) using the South Bay Race Chart. If the Herreshoff S Class is assigned to the Red Fleet, they may sail courses as described in Appendix B or Appendix D.

B1 COURSES USING SOUTH BAY RACING CHART

Special courses will be designated using buoys as described on the 2012-2014 South Bay Race Chart provided at registration. (Note: Designated courses from the back of the South Bay Race Chart will not be used.)

- a) The Race Committee will list the marks on a white board in the order to be rounded and the required side to leave the mark using the designations on the 2012-2014 South Bay Race Chart.
- b) **Newport Bridge** – Yachts shall pass through the **center span only** for any course passing under the Newport Bridge. For the purposes of rule 32.2(c), the center span shall be considered a gate.
- c) Special Mark “U”
 - The Race Committee may add a first mark to any course by displaying flag “U”.
 - If “U” is used, there will be either a Green or Red flag displayed below “U” to designate the direction to be rounded. Mark “U” is to be rounded either to STARBOARD (Green flag below “U”), or to PORT (Red flag below “U”).
 - Special Mark “U” will be positioned approximately 0.5 NM to windward from the RC signal boat.
 - Mark “U” will be a YELLOW tetrahedron buoy.
- d) The course will be:
 - Start
 - Special Mark “U” if used
 - Round the marks in the designated order leaving each mark to the designated side
 - Finish
- e) The finishing mark will be on the opposite side of the Race Committee Signal Boat from the starting mark.

B2 MARKS

- B2.1 Mark “U”, if used, will be a YELLOW tetrahedron buoy. The starting mark will be a 5’ YELLOW tetrahedron buoy. The finishing mark will be a 5’ ORANGE tetrahedron buoy.
- B2.2 Special NYYC Temporary Inflatable Race Marks 16 and 17 as designated on the 2012-2014 South Bay Race Chart, if used, will be 8’ ORANGE tetrahedron buoys.

SAILING INSTRUCTIONS

Appendix C – DROP MARK RACES

Saturday-Sunday, June 15-16

The Blue and White fleets on Saturday and Sunday will race on courses as described below:

C1 COURSES FOR DROP MARK RACES

C1.1 Course Diagrams

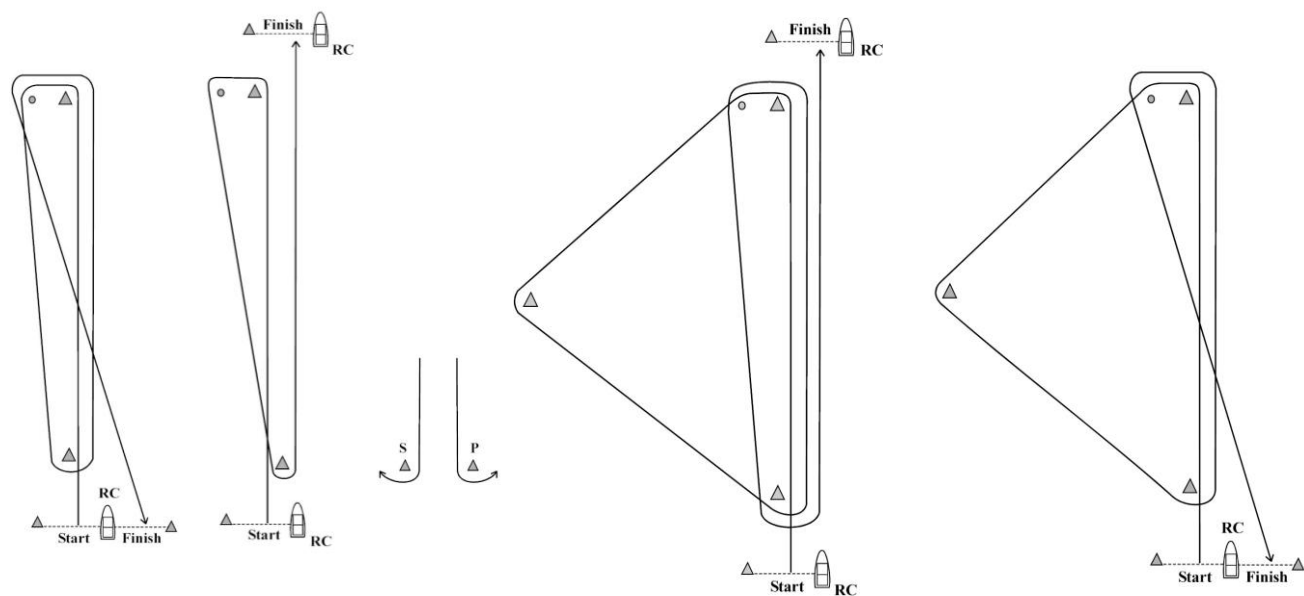

Course “W”
Even # legs

Course “W”
Odd # legs

Gate
Marks

Course “O”

Course “K”

C1.2 **Course “W”** is a Windward/Leeward course with a windward offset mark. A numeral pennant indicating the number of **LEGS** to be raced will be flown beneath Flag “W”. The distance between the windward mark and the offset mark shall not count as a leg for the purposes of indicating the number of legs.

C1.3 **Course “O”** is a Triangle/Windward/Leeward/Windward course.

C1.4 **Course “K”** is a Triangle/Windward/Leeward course.

C1.5 The leeward mark for Courses “W”, “O”, and “K” will be an inflatable mark(s) set approximately 0.10 NM to windward of the starting line. A gate mark may be used for Course “W”.

C1.6 The course designation, distance and bearing to the windward mark will be signaled using flags displayed on poles. The course designation will be flown forward, followed by the three numeral pennants designating the magnetic bearing to the first mark, followed by the two numeral pennants designating distance (nautical miles and tenths) to the first mark.

C1.7 Marks, including the windward offset mark, shall be rounded in order and left to port, except that a gate, when used, shall be rounded as described rule 28.1(c).

C1.8 There will be a windward offset mark adjacent to the windward mark for all drop mark courses except as noted for the Blue Fleet in SI C1.9.

C1.9 This instruction applies to the **BLUE FLEET** only:

- For course “W” with an even number of legs, the Race Committee may set a long windward mark and a short windward mark.
- The distance displayed will be to the SHORT windward mark. The long windward mark will be on the same bearing at a distance of 1.0 NM beyond the short windward mark.
- The long windward mark will have a black band and there will be no offset mark.
- If flag “U” is displayed with the course signals, that class will sail to the LONG windward mark. If flag “U” is NOT displayed with the course signals, that class will sail to the SHORT windward mark.

This changes the diagrams in SI Appendix C 1.1, as well as SI Appendix C 1.2, 1.7, 1.8 and 2.2.

C2 MARKS FOR COURSES “W”, “O”, and “K”:

C2.1 Marks will be inflatable tetrahedron buoys as follows:

<u>Fleet</u>	<u>Original marks</u>	<u>Change marks</u>	<u>Starting</u>	<u>Finishing</u>
BLUE	Yellow 8’	Orange 8’	Orange 5’	Yellow 5’
WHITE	Orange 8’	Yellow 8’	Yellow 5’	Orange 5’

C2.2 Offset marks will be small round orange buoys.

C3 COURSE CHANGE

C3.1 In addition to the requirements in rule 33, the Race Committee will attempt to announce any course change on their respective fleet VHF channel. Failure to make such an announcement shall not be grounds for redress. This changes rule 62.1(a).

C3.2 The new mark will be a different color (orange or yellow) from the original mark as described in SI Appendix C 2.1. For a subsequent change, the new mark will be the same as the original mark.

C4 THE FINISH

C4.1 The finishing line will be between a staff displaying an orange flag on a Race Committee Boat and the finishing mark.

- a) For Course “W”, with an odd number of legs, and Course “O”, the finish line will be located approximately 0.1 NM to windward of the windward mark.
- b) For Course “W”, with an even number of legs, and Course “K”, the finish line will be located approximately 0.1 NM to leeward of the leeward mark and the finishing mark will be on the opposite side of the Race Committee Signal Boat from the starting mark. See diagrams in SI Appendix C 1.1.

C4.2 If a subsequent race is to be sailed, the finish line Race Committee Boat intends to fly Pennant “Second Substitute” with the Blue “On-Station” signal at the finish. If a Class Flag is displayed below Pennant “Second Substitute” the subsequent race is for that class(es) only. In addition, the Race Committee will attempt to announce a subsequent race on their respective fleet VHF channel.

C4.3 In fog at the finish, the Race Committee Boat may ring a bell rapidly, for approximately 5 seconds, at intervals. The same Race Committee Boat may or may not start and finish each race.

SAILING INSTRUCTIONS

Appendix D – RED FLEET DROP MARK RACES

Saturday-Sunday, June 15-16

Herreshoff S Class – If assigned to the Red Fleet, courses will be as described in either SI Appendix B – South Bay Race Chart Course, or this Appendix D – Red Fleet Drop Mark Races.

All other classes - It is the intention of the Race Committee to use the drop mark course described below for one-design classes on the Red Fleet circle.

D1 COURSES FOR DROP MARK RACES

D1.1 Course Diagram

D1.2 **Course** – The course is a Windward/Leeward course and will be designated by flag “W” over a numeral pennant indicating the number of legs. The offset leg will not count in the total number of legs. Marks, including the windward offset mark, shall be rounded in order and left to port, except that a gate, when used, shall be rounded as described rule 28.1(c).

SAMPLE: W4 Start – W – Offset – L – W – Offset – Finish

D1.3 The leeward mark will be an inflatable mark(s) set approximately 0.10 NM to windward of the starting line. A gate mark may be used.

D1.4 When the windward mark is changed in accordance with SI D3, there will not be an offset mark.

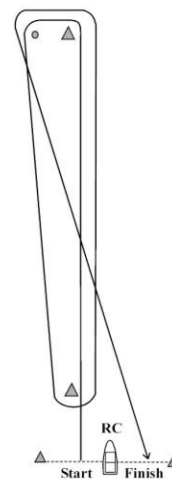

D2 MARKS

D2.1 Marks will be inflatable buoys as follows:

<u>Fleet</u>	<u>Original marks</u>	<u>Offset mark</u>	<u>Change mark</u>	<u>Starting</u>	<u>Finishing</u>
RED	Orange 5’ tetrahedron	Orange cylinder	Yellow 5’ tetrahedron	Pink 5’ tetrahedron	Green 5’ tetrahedron

D3 COURSE CHANGE

In addition to the requirements in rule 33, the Race Committee will attempt to announce any course change on VHF channel 77. If the direction of the leg is changed, it will be signaled in accordance with rule 33(a)(2). Failure to make such an announcement shall not be grounds for redress. This changes rule 62.1(a).

D4 THE FINISH

D4.1 The finishing line will be between a staff displaying an orange flag on a Race Committee Boat and the finishing mark. The finishing mark will be on the opposite side of the Race Committee Signal Boat from the starting mark. See diagram in SI Appendix D 1.1.

D4.2 The Race Committee will attempt to announce a subsequent race on VHF channel 77.

D4.3 In fog at the finish, the Race Committee Boat may ring a bell rapidly, for approximately 5 seconds, at intervals. The same Race Committee Boat may or may not start and finish each race.

SAILING INSTRUCTIONS

Appendix E – FARR 40 CLASS

These Sailing Instructions apply only to racing on Thursday and Friday, June 13-14. Racing on Saturday and Sunday, June 15-16, will be run in accordance with the Sailing Instructions for the 159th NYYC Annual Regatta except as changed by paragraphs 1, 7.2, 15.1 and 19 in this Appendix.

E1 RULES

- E1.1 This Regatta will be governed by the *rules* as defined in the *Racing Rules of Sailing* (RRS) and the Farr 40 Class Rules.
- E1.2 Boats shall comply with the current ISAF Offshore Special Regulations, Category 4 (except neither 5.01.1 (a, b, c, f) nor 4.26.4(g) shall apply for this event). In the event of conflict, designer and manufacturers original standards shall prevail.
- E1.3 Delete the first and second sentences of RRS 44.1 and substitute the following:
A boat may take a One-Turn Penalty, consisting of one tack and one gybe, when she may have broken a rule of Part 2, Rule 31, or Rule 42 while *racing*. However, if a boat may have broken a rule of Part 2 within the three-length zone of a rounding mark or finishing mark, the penalty that may be taken is a Two-Turns Penalty. This changes RRS 44.1.
- E1.4 When leaving the dock, boats shall carry a minimum of 1.5 liters of drinkable liquid, up to a maximum of 4 liters, per person per day. This liquid is included in the restrictions for movable ballast in RRS 51, except when consumed by a crew member.
- E1.5 In RRS 61.1(a), after the second sentence, add the following words: “The red flag shall have the minimum dimensions of 45cm x 45 cm and shall be displayed vertically from the backstay.” This changes RRS 61.1.
- E1.6 Video, electronic data and/or photographs taken from any source shall not be used as evidence at protest hearings. This changes RRS 63.6.
- E1.7 Where there is conflict with the Notice of Race, these Sailing Instructions shall prevail. This changes RRS 63.7.

E2 NON-COMPETING CLASS REPRESENTATIVE

Will be Geoff Stagg +1 443 336 1682.

E3 NOTICES TO COMPETITORS

- E3.1 Notices to competitors will be posted on the Official Notice Board located at the NYYC Sailing Center Harbour Court.
- E3.2 The Race Committee may broadcast race information on VHF Channel 72 before and during each race. Failure of such communication to be given or received, or the order in which OCS calls are broadcast, shall not be grounds for redress, except when a request for redress under this instruction is initiated by the Race Committee or Protest Committee. This changes RRS 62.1.

E4 CHANGES TO SAILING INSTRUCTIONS

- E4.1 Changes to the schedule will be posted by 2000 on the day before they will take effect and shall be approved by the Class representative. Other changes will be posted before 0900 hrs on the day they take effect.
- E4.2 Changes to the Sailing Instructions made afloat will be indicated by the display of Code Flag 3rd Substitute accompanied by two sound signals. The change may be communicated either orally or in writing.

E5 SIGNALS MADE ASHORE

- E5.1 Signals made ashore will be displayed on the flagpole at Harbour Court.
- E5.2 The Warning Signal will not be made less than 60 minutes after “AP” is lowered ashore. This changes RRS Race Signals “AP”.

E6 RACING AREA

Races will be held off Newport, RI, on Rhode Island Sound or in Narragansett Bay. The Race Committee will announce the location of the race course over VHF Channel 72 at 0900 on Thursday and Friday mornings, June 13-14. The failure to make this announcement, or for a yacht to hear this announcement, will not be grounds for redress. This change RRS 62.1(a).

E7 SCHEDULE OF RACES

E7.1 June 13-14 First Course Signal – 1100 First Warning Signal – 1105

E7.2 It is the intent of the Race Committee to conduct as many races as practicable, not to exceed three (3) races on any day, up to a maximum of 11 races for the four-day event. No Warning Signal will be made after 1400 hours on the last scheduled day of racing.

E8 COURSES

E8.1 The Race Committee Signal Boat will signal the Course Number, the approximate magnetic bearing and distance in nautical miles from the Race Committee Signal Boat to Mark 1.

Course 2: Start - 1 - 1a – Finish (Downwind)

Course 3: Start - 1 - 1a - Gate – Finish (Upwind)

Course 4: Start - 1 - 1a - Gate - 1 - 1a – Finish (Downwind)

Course 5: Start - 1 - 1a - Gate - 1 - 1a - Gate – Finish (Upwind)

Course 6: Start - 1 - 1a - Gate - 1 - 1a - Gate- 1 - 1a – Finish (Downwind)

E8.2 (a) Marks 1 and 1a shall be rounded to port. Mark 1a is an offset mark and will be positioned to port of Mark 1.

(b) In the event Mark 1a is not in place the boats shall round Mark 1 to port

E8.3 (a) In the event that a Gate is not in place, boats shall round the existing Leeward mark to port.

(b) Except when there is a change of course, the Gate will be positioned approximately to windward of the Race Committee Signal Boat.

(c) The Gate may be laid after the starting signal.

E8.4 Except for when there is a change of course:

(a) The Finish for course 2, 4 and 6 will be downwind of the Gate; and

(b) The Finish for course 3 and 5 will be upwind of Mark 1.

E9 MARKS

E9.1 Marks 1, 1a, port gate and starboard gate will be orange inflatable buoys

E9.2 The starting mark and finishing mark will be a yellow inflatable buoy.

E9.3 As provided in instruction 12, new marks 1, 1a and gate marks will be the same as the original marks.

E10 THE START

The starting line will be between a staff displaying an orange flag on the Race Committee Signal Boat and a starting mark.

E11 FINISH

E11.1 The finishing line will be between the staff displaying an orange flag on the Race Committee Signal Boat and a finishing mark.

E11.2 The finishing line may be a shorter length than the starting line.

E12 CHANGE OF THE NEXT LEG OF THE COURSE

When changing the course, the original inflatable buoys will be moved, although they may not yet be in position before the leading boat begins that leg of the course. If a change of course is signaled for a windward leg, Mark 1a (the "offset") will also be placed in position and shall be rounded to port. (See also 8.2 (b).)

E13 TIME LIMIT

- E13.1 The time limit shall be 90 minutes.
- E13.2 Boats failing to finish within 15 minutes after the first boat sails the course and finishes will be scored points for the finishing place equal to the number of boats that finished that race plus 2. This changes RRS 35 and A4.

E14 PROTESTS AND REQUESTS FOR REDRESS

- E14.1 The protest time limit is ninety (90) minutes after the last boat finishes in the last race of that day.
- E14.2 Notices will be posted within thirty (30) minutes after expiration of the protest time limit to inform competitors of hearings in which they are parties or named as witnesses. Protest hearings will take place at the NYYC Sailing Center as soon as possible after the notices are posted. The Protest Committee will attempt to hear protests in the order of receipt. Representatives of yachts who are parties to a hearing shall remain on call in the vicinity of the protest rooms.
- E14.3 The penalty, if any, for any infringement of the rules (including the Class Rules and ISAF Offshore Special Regulations, Category 4) other than RRS Part 2 is at the sole discretion of the Protest Committee in consultation with the Class representative, and may be other than disqualification. This changes RRS 64.1.
- E14.4 On the last day of the regatta a request for reopening a hearing shall be delivered:
- (a) within the protest time limit if the party requesting reopening was informed of the decision on the previous day;
 - (b) no later than thirty (30) minutes after the party requesting reopening was informed of the decision on that day. This changes RRS 66.
- E14.5 The Protest time limit for sailor classification is 90 minutes after the last boat finishes in the last race of Day 1.

E15 FLAGS AND DECALS ON BOATS

- E15.1 Class flag: Boats shall fly the special F40 flag on the backstay approximately six feet above the deck as their designated class flag from the time they leave the dock for the first day of racing until they arrive back at the dock on the last day of racing.
- E15.2 The Rolex backstay flag provided at registration shall be displayed while racing and placed just under the class flag.
- E15.3 The Rolex bow stickers provided at registration shall be displayed while racing.

E16 SCORING - Refer 2013 Annual Regatta NOR Addendum 4 paragraph 13.

E17 REGISTRATION - Refer 2013 Annual Regatta NOR Addendum 4 paragraphs 4.5 and 6.

E18 MEASUREMENT - Refer 2013 Annual Regatta NOR Addendum 4 paragraph 8.

E19 HAUL-OUT RESTRICTIONS

Yachts may be hauled out after hull weighing and during the regatta only with the prior written permission of the Protest Committee, and under such terms as they may decide. Normally, the Protest Committee shall grant such permission only if necessary to repair damage. While hauled out, bottoms and foils shall not be sanded, polished, washed, or otherwise worked on except as permitted by the Protest Committee in the area of repair. Hulls and appendages may be cleaned in the water.

E20 PRIZES - Refer 2013 Annual Regatta NOR Addendum 4 paragraph 14.

E21 DISCLAIMER OF LIABILITY - Refer 2013 Annual Regatta NOR Addendum 4 paragraph 15.

E22 SUPPORT BOATS - Refer 2013 Annual Regatta NOR Addendum 4 paragraph 17.

SAILING INSTRUCTIONS

Appendix F – NYYC PRIMARY RACE AREAS

