



NEW YORK YACHT CLUB RACE WEEK AT NEWPORT

Presented by Rolex

July 14-22, 2012
Newport, Rhode Island



SAILING INSTRUCTIONS – PART III

GENERAL

One-Design and Handicap classes racing Thursday-Sunday, July 19-22; J/111 class racing Friday-Sunday, July 20-22; J/105 class, Melges 32 and PHRF “Navigator” classes racing Saturday and Sunday, July 21-22.

1 RULES

- 1.1 The regatta will be governed by the rules as defined in *The Racing Rules of Sailing* (RRS).
- 1.2 The Race Week website can be found at <http://nyyc.org/nyycrace-week-jul14-22/>.
- 1.3 **Check-in:** Each yacht shall register at the check-in desk at the NYYC Sailing Center at Harbour Court prior to racing at the times so designated in the Notice of Race.
- 1.4 **Crew Waiver:** No crew shall be aboard a yacht while racing unless he/she has executed the online Crew Waiver Form. The Crew Waiver Forms are available on the Race Week website. Registration will not be complete without receipt of a complete Crew Waiver Form.
- 1.5 **Offshore Special Regulations: Offshore Special Regulations:** At minimum, all yachts shall comply with the 2012-2013 ISAF Offshore Special Regulations (OSR), Category 5 posted as NOR Addendum 1 on the Race Week website and shall comply with their class rules, where applicable. In the event of a conflict between these regulations and applicable class rules, the class rules shall apply.
 - a) Yachts that are not normally rigged with lifelines are exempt from Regulation 3.14.
 - b) All competitors, and in particular the person in charge, shall be fully aware of and understand the responsibilities described in OSR 1.02 and RRS 4:

1.02 Responsibility of Person in Charge

1.02.1 The safety of a yacht and her crew is the sole and inescapable responsibility of the person in charge who must do his best to ensure that the yacht is fully found, thoroughly seaworthy and manned by an experienced crew who have undergone appropriate training and are physically fit to face bad weather. He must be satisfied as to the soundness of hull, spars, rigging, sails and all gear. He must ensure that all safety equipment is properly maintained and stowed and that the crew know where it is kept and how it is to be used.

ADD: He shall also nominate a person to take over the responsibilities of the Person in Charge in the event of his incapacitation.

1.02.2 Neither the establishment of these Special Regulations, their use by race organizers, nor the inspection of a yacht under these Special Regulations in any way limits or reduces the complete and unlimited responsibility of the person in charge.

1.02.3 Decision to race -The responsibility for a yacht's decision to participate in a race or to continue racing is hers alone - RRS Fundamental Rule 4.

- 1.6 The prescriptions of US SAILING that are posted as NOR Addendum 2 on the Race Week website shall apply.
- 1.7 The Protest Committee may impose suitable penalties, other than disqualification, for violations of the ISAF Offshore Special Regulations or other non-Part 2 rules. This changes RRS 64.1.
- 1.8 The 2012 IRC Rules and Regulations shall apply to yachts racing under IRC.
- 1.9 The 2012 PHRF-NB Regulations shall apply to yachts racing under PHRF.

- 1.10 The current class rules shall apply to all yachts racing as a one-design class, except as noted in these sailing instructions.
- 1.11 J/109 Class only:
In accordance with NOR 2.2, Sailing Instructions Addendum A (posted online) pertains to J/109s participating in their 2012 North American Championship to be held as part of New York Yacht Club Race Week. Where there is a conflict between SI Addendum A and the Notice of Race or the Sailing Instructions, SI Addendum A shall prevail. This changes RRS 63.7.
- 1.13 J/105 Class only:
This is a Class Level A event in accordance with Class Rule 3.7. Class Rule 7.1, maximum crew weight, shall apply. There will be no weigh-in at registration.
- 1.14 J/111 Class only:
In accordance with NOR 2.2, Sailing Instructions Addendum B (posted online) pertains to J/111s participating in New York Yacht Club Race Week. Where there is a conflict between SI Addendum B and the Notice of Race or the Sailing Instructions, SI Addendum B shall prevail. This changes RRS 63.7.
- 1.15 Swan 42 Class only:
The Swan 42 National Championship will include four days of racing. A distance race will be scheduled on one of the four days and the Class will be informed of the intention to sail the distance race no later than 2000 on the day before. One-design inshore sails shall be used for all racing including the distance race. The distance course description is attached as SI Appendix D.

2 ENTRIES

Eligible yachts shall enter by completing online registration with the Organizing Authority on the Race Week website. Eligibility requirements for yachts and method of entry are detailed in the Notice of Race.

3 NOTICES, COMPETITOR INFORMATION AND SIGNALS MADE ASHORE

- 3.1 Notices, including race results, amendments and protest hearing schedules, shall be posted on the Official Notice Board located in the courtyard of the NYYC Sailing Center at Harbour Court. This information may also be posted on the Race Week website.
- 3.2 Flag signals will be flown from the flagpole at Harbour Court.
- 3.3 Any change to the sailing instructions will be posted before 0900 on the day it will take effect, except that any change to the schedule of races will be posted by 2000 on the day before it will take effect. Flag “Lima” will be flown to signify such posting.
- 3.4 When “AP” is displayed ashore, “one minute” is replaced with “not less than one hour” in Race Signal “AP”.
- 3.5 Signals designating the rendezvous locations will be displayed at 0900 each race day from the flagpole at Harbour Court. The Race Committee will endeavor to announce the fleet assignments and the rendezvous locations as described in SI 6 at that time over VHF Channel 72. The failure to make this announcement or for a yacht to hear this announcement will not be grounds for redress. This changes rule 62.1(a).
- 3.6 After the rendezvous locations and any other regatta announcements have been made, Race Committee Signal Boats will monitor and communicate with their respective fleets on the VHF channels published in SI 4.3.

4 CLASSES AND IDENTIFICATION

- 4.1 The Organizing Authority will divide yachts into classes. Classes will be assigned a numeral designation and assigned each day to one of three fleets (Blue, White, Green). Note that a class may sail in different fleets on different days.
- 4.2 **Scratch Sheets** - The scratch sheets will be distributed at registration, posted on the Official Notice Board and posted on the regatta website.
- 4.3 **VHF Channels** - The Race Committee VHF channels for each fleet are shown below:

Blue Fleet	VHF Channel 72
White Fleet	VHF Channel 69
Green Fleet	VHF Channel 71

- 4.4 **Backstay Flags** – Each yacht shall display the flag corresponding to her class designation, as shown on the scratch sheet, from her backstay approximately six feet above the deck and above the Rolex flag, from the warning signal of the first class in her fleet until she is no longer racing.
- 4.5 **Bow Stickers and Flags** - Each yacht shall display the Rolex backstay flag and bow stickers provided at registration while racing.

5 SCHEDULE OF RACES

- 5.1 All races will count in the series. The first warning signal for each fleet is scheduled for 1100 on each race day.
- 5.2 Navigator Races - There will be one race on Saturday, July 21, and one race on Sunday, July 22. Each race will be scored separately.
- 5.3 No warning signal shall be made after 1500 on Sunday, July 22.

6 RENDEZVOUS LOCATIONS

Fleet rendezvous locations are listed below and will be designated as described in SI 3.5.

Rhode Island Sound:

- Area “A” - in the vicinity of 160° for 1.2 NM from R “2” QR Whistle marking Brenton Point
- Area “B” - in the vicinity of 120° for 2.5 NM from R “2” QR Whistle marking Brenton Point
- Area “C” - in the vicinity of 225° for 2.0 NM from R “2” QR Whistle marking Brenton Point
- Area “D” - in the vicinity of 200° for 3.5 NM from R “2” QR Whistle marking Brenton Point
- Area “E” - in the vicinity of 165° for 2.5 NM from R “2” QR Whistle marking Brenton Point
- Area “F” - in the vicinity of 150° for 4.5 NM from R “2” QR Whistle marking Brenton Point

Newport Harbor and near Newport Bridge:

- Area “J” - in the vicinity of Mackerel Cove (Conanicut Island opposite Castle Hill)
- Area “K” - between Goat Island and Rose Island
- Area “M” - in the vicinity of R “12” west of Rose Island
- Area “N” - off Coasters Harbor Island (just north of east end of Newport Bridge)
- Area “O” - in the vicinity of Potter Cove (just north of west end of Newport Bridge)

North of Newport Bridge:

- Area “R” - in the vicinity of 200° for 0.5 NM from Halfway Rock
- Area “S” - in the vicinity of RG Nun south of Prudence Island
- Area “T” - in the vicinity of G “7” QG off Quonset Point
- Area “U” - in the vicinity of C “1” northeast of Hope Island.
- Area “V” - in the vicinity of C “5” 290° for 1.0 NM from Pine Hill Point on Prudence Island
- Area “W” - in the vicinity of G “1” 0.9 NM southwest of Hog Island

7 CHECK-IN AND RETIREMENT

- 7.1 Prior to the warning signal for the first race each day, all yachts shall check in with the Race Committee Signal Boat by passing astern on starboard tack and announcing their sail number. The Race Committee will acknowledge by responding with the number heard.
- 7.2 Yachts retiring are requested to inform the Race Committee on their fleet VHF channel or by calling (401) 845-9633.

8 COURSES & MARKS

The courses and marks are described in the SI Appendices as follows:

PHRF Navigator Races	SI Appendix A
Drop Mark Races	SI Appendix C
Swan 42 Distance Race	SI Appendix D

9 THE START

- 9.1 Races will be started in accordance with rule 26.

- 9.2 A yacht starting later than 20 minutes after her starting signal will be scored Did Not Start. This changes rule A4.
- 9.3 The starting line will be between a staff displaying an orange flag on the Race Committee Signal Boat and the course side of the port-end starting mark. The Race Committee may deploy a “Keep Off” buoy(s) that shall be considered an integral part of the Race Committee Signal Boat.
- 9.4 Yachts whose warning signal has not been made shall keep clear of the starting area.

10 INDIVIDUAL RECALLS

The Race Committee will endeavor to hail each premature starter over their respective fleet VHF channel. Failure to make such an announcement shall not be grounds for redress. This changes rule 62.1(a).

11 THE FINISH

The finishing line is described in the relevant SI Appendix.

12 GOVERNMENT BUOYS

Government buoys have no required side except when specified as marks of the course. Caution should be exercised for safe navigation.

13 PENALTY SYSTEM

- 13.1 If class rules specify a penalty, a yacht that may have broken a rule of Part 2 while racing may take a penalty at the time of the incident as provided in her class rules.
- 13.2 If the class rules do not specify a penalty, rule 44.1 is changed so that a yacht has the choice between penalty systems, and the Two-Turns Penalty is replaced by the One-Turn Penalty. A yacht may choose either to:
- take a One-Turn Penalty in accordance with rule 44.2; or
 - take a Scoring Penalty in accordance with rule 44.3.

14 TIME LIMIT

- 14.1 The time limit to sail the course and finish is as follows:
- For a Navigator Race course - four hours.
 - For a drop mark course - three hours.
- 14.2 Yachts failing to finish within 60 minutes of the first yacht in her class to sail the course and finish, or within the time limit, whichever is later, will be scored Did Not Finish (DNF) and scored points as described in SI 16.3. This changes rules 35 and A4.

15 PROTESTS AND REQUESTS FOR REDRESS

- 15.1 A yacht intending to protest shall report both their intention and the yacht being protested to the Race Committee on the fleet VHF channel at the finish of the race.
- 15.2 Written protests or requests for redress shall be submitted to the Jury Secretary in the NYYC Sailing Center as soon as possible, but not later than one hour after the Race Committee Signal Boat for that fleet has docked. The time limit for filing a protest will be posted on the Official Notice Board.
- 15.3 Protest notices will be posted as soon as possible on the Official Notice Board.
- 15.4 Protest hearings will take place at the NYYC Sailing Center as soon as possible after the notices are posted. The Jury will attempt to hear protests in the order of receipt. Representatives of yachts who are parties to a hearing shall remain on call in the vicinity of the protest rooms.
- 15.5 When a yacht has been involved in an incident that may be subject to protest, it is her responsibility to check the protest notices at the end of the protest filing time to see if she is cited in a protest. Failure of any yacht to appear when called for a hearing will be considered by the Jury as grounds for proceeding under rule 63.3(b).
- 15.6 Rule 63.5 is changed by adding, “A protest involving contact may be heard by the Protest Committee even though the requirements of rule 61.1(a) and 61.3 have not been fulfilled.”
- 15.7 Breaches of SIs 4.4, 4.5, 7, 9.4 and 18.2 will not be grounds for a protest by a yacht. This changes rule 60.1(a).
- 15.8 A violation of SI 18.2 will be considered “a gross breach of a *rule*” under rule 69.1(a).

- 15.9 On the last scheduled day of racing only, a written request for reopening a hearing shall be delivered to the Jury Secretary:
- a) Within the protest time limit if the requesting party was informed of the Protest Committee's decision on the previous day; or
 - b) No later than 30 minutes after the requesting party was informed of the Protest Committee's decision on that day; or
 - c) If no races are held on the last scheduled day of racing, within one hour after racing has been abandoned.
- This changes rule 66.
- 15.10 On the last scheduled day of racing, a request for redress based on a Protest Committee decision shall be delivered in writing no later than 30 minutes after the decision was posted. This changes rule 62.2.

16 SCORING

- 16.1 A yacht's series score will be the total of her race scores. There will be no drop race. This changes rule A2.
- 16.2 One race is required to be completed to constitute a series.
- 16.3 Yachts that have started and failed to finish within the time limit for any reason, shall, without a hearing, be scored by the Race Committee with points equal to the number of yachts in her class that have sailed the course and finished within the time limit, plus two. This changes rule A4.1, A4.2, and A5.

17 PRIZES

Prizes will be awarded as described in the Notice of Race.

18 NOTES

- 18.1 Competitors are reminded that Narragansett Bay and its approaches are considered restricted channels for commercial traffic and other vessels restricted in their ability to maneuver. Competitors must comply with the government right-of-way rules when in proximity to commercial or privileged marine traffic.
- 18.2 In the event there is racing in Narragansett Bay, competitors should be aware of heightened security around the Navy base in Newport just to the north of the Newport Jamestown Bridge. The area to the east of a line defined by a series of white buoys marking the Newport Security Zone along the coast of the Naval Facilities from Coasters Harbor to the breakwater at the north end of Coddington Cove shall rank as an obstruction. Yachts shall not enter this area. A Navy patrol boat monitors the area and vessels navigating in the Exclusionary Zone may face action by Coast Guard and Naval authorities.
- 18.3 All times herein are Eastern Daylight times. Bearings are in degrees magnetic and are approximate. Distances used herein are expressed in nautical miles (when not otherwise defined) and are approximate.

18.4 Newport Tides

Day	Date	High Tide	Low Tide
Thursday	July 19	0838	1403
Friday	July 20	0919	1447
Saturday	July 21	1001	1529
Sunday	July 22	1046	1612

18.5 For further information please contact:

New York Yacht Club, Harbour Court
 5 Halidon Avenue, Newport, RI 02840
 Tel: 401-845-9633
 Fax: 401-846-3303
 Email: sailingoffice@nyyc.org
 Website: www.nyyc.org/157th-annual-regatta/

SAILING INSTRUCTIONS - APPENDIX A

Part III –Navigator Races - Saturday-Sunday, July 21-22

Courses will be designated using the South Bay Race Chart as follows:

A1 COURSES USING SOUTH BAY RACING CHART

Special courses will be designated using buoys as described on the 2009-2012 South Bay Race Chart provided at registration. Do not use older versions of the Race Chart. (Note: Designated courses from the back of the South Bay Race Chart will not be used.)

- a) The Race Committee will list the marks on a white board in the order to be rounded and the required side to leave the mark using the designations on the 2009-2012 South Bay Race Chart.
- b) **Newport Bridge** – Yachts shall pass through the **center span only** for any course passing under the Newport Bridge. For the purposes of rule 32.2(c), the center span shall be considered a gate.
- c) Special Mark “U”
 - The Race Committee may add a first mark to any course by displaying flag “U”.
 - If “U” is used, there will be either a Green or Red flag displayed below “U” to designate the direction to be rounded. Mark “U” is to be rounded either to STARBOARD (Green flag below “U”), or to PORT (Red flag below “U”).
 - Special Mark “U” will be positioned approximately 0.5 NM to windward from the RC signal boat.
 - Mark “U” will be a YELLOW tetrahedron buoy.
- d) The course will be:
 - Start
 - Special Mark “U”, if used
 - Round the marks in the designated order leaving each mark to the designated side
 - Finish
- e) The finishing mark will be on the opposite side of the Race Committee Signal Boat from the starting mark. Note that the Race Committee may shorten the course to finish at a rounding mark or gate in accordance with rule 32.

A2 MARKS

- A2.1 Mark “U”, if used, will be a YELLOW tetrahedron buoy. The starting mark will be an ORANGE tetrahedron buoy. The finishing mark will be a YELLOW tetrahedron buoy.
- A2.2 Special NYYC Temporary Inflatable Race Marks 16 and 17 as designated on the 2009-2012 South Bay Race Chart, if used, will be ORANGE tetrahedron buoys.

SAILING INSTRUCTIONS – APPENDIX C

Part III – DROP MARK RACES – Thursday-Sunday, July 19-22

The Blue, White and Green fleets on July 19-22, will race on courses as described below except as described elsewhere in these sailing instructions.

C1 COURSES FOR DROP MARK RACES

C1.1 Course Diagrams

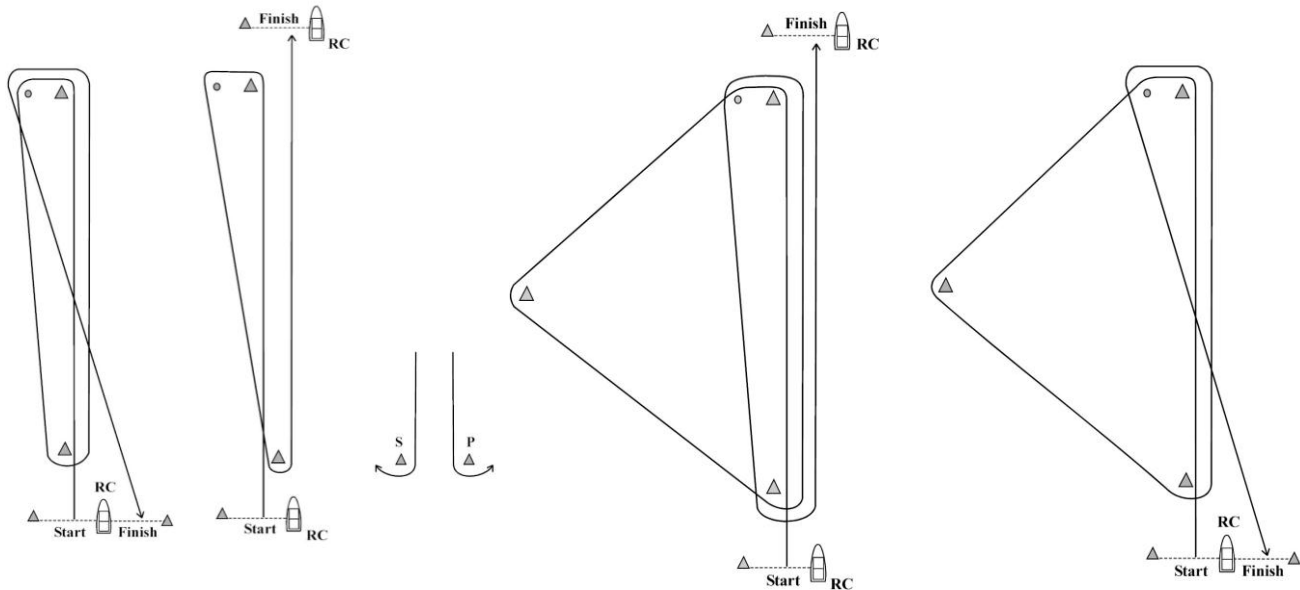

Course "W"
Even # legs

Course "W"
Odd # legs

**Gate
Marks**

Course "O"

Course "K"

C1.2 **Course "W"** is a Windward/Leeward course with a windward offset mark. A numeral pennant indicating the number of **LEGS** to be raced will be flown beneath Flag "W". The distance between the windward mark and the offset mark shall not count as a leg for the purposes of indicating the number of legs.

C1.3 **Course "O"** is a Triangle/Windward/Leeward/Windward course.

C1.4 **Course "K"** is a Triangle/Windward/Leeward course.

C1.5 The leeward mark for Courses "W", "O", and "K" will be an inflatable mark(s) set approximately 0.10 NM to windward of the starting line. For the White and Blue fleets, a gate mark may be used for Course "W".

C1.6 The course designation, distance and bearing to the windward mark will be signaled using flags displayed on poles. The course designation will be flown forward, followed by the three numeral pennants designating the magnetic bearing to the first mark, followed by the two numeral pennants designating distance (nautical miles and tenths) to the first mark.

C1.7 Marks, including the windward offset mark, shall be rounded in order and left to port, except that a gate, when used, shall be rounded as described in rule 28.1(c).

C1.8 There will be a windward offset mark adjacent to the windward mark for all drop mark courses except as noted in C1.9(c).

C1.9 This instruction applies to the **BLUE FLEET** only:

- a) For course “W” with an even number of legs, the Race Committee may set a long windward mark and a short windward mark.
- b) The long windward mark will have a black band and there will be no offset mark.
- c) If flag “U” is displayed with the course signals, that class will sail to the LONG windward mark and the distance to that mark will be displayed beneath flag “U” by two numeral pennants (nautical miles and tenths).

This changes the diagrams in Appendix C 1.1, as well as Appendix C 1.2, 1.7, 1.8 and 2.2.

C2 MARKS FOR COURSES “W”, “O”, and “K”:

C2.1 Marks will be inflatable tetrahedron buoys as follows:

<u>Fleet</u>	<u>Original marks</u>	<u>Starting</u>	<u>Finishing</u>	<u>Change marks</u>
WHITE	Yellow 8’	Orange 5’	Yellow 5’	Orange 8’
BLUE	Orange 8’	Yellow 5’	Orange 5’	Yellow 8’
GREEN	Yellow 8’	Orange 5’	Yellow 5’	Orange 8’

C2.2 Offset marks will be small round orange buoys.

C3 COURSE CHANGE

C3.1 In addition to the requirements in rule 33, the Race Committee will attempt to announce any course change on their respective fleet VHF channel. Failure to make such an announcement shall not be grounds for redress. This changes rule 62.1(a).

C3.2 The new mark will be a different color (orange or yellow) from the original mark as described in SI Appendix C 2.1. For a subsequent change, the new mark will be the same as the original mark.

C4 THE FINISH

C4.1 The finishing line will be between a staff displaying an orange flag on a Race Committee Boat and the finishing mark.

- a) For Course “W”, with an odd number of legs, and Course “O”, the finish line will be located approximately 0.1 NM to windward of the windward mark.
- b) For Course “W”, with an even number of legs, and Course “K”, the finish line will be located approximately 0.1 NM to leeward of the leeward mark and the finishing mark will be on the opposite side of the Race Committee Signal Boat from the starting mark. See diagrams in SI Appendix C 1.1.

C4.2 If a subsequent race is to be sailed, the finish line Race Committee Boat intends to fly Pennant “Second Substitute” with the Blue “On-Station” signal at the finish. If a Class Flag is displayed below Pennant “Second Substitute” the subsequent race is for that class(es) only. In addition, the Race Committee will attempt to announce a subsequent race on their respective fleet VHF channel.

C4.3 In fog at the finish, the Race Committee Boat may ring a bell rapidly, for approximately 5 seconds, at intervals. The same Race Committee Boat may or may not start and finish each race.

SAILING INSTRUCTIONS – APPENDIX D

SWAN 42 NATIONALS – Distance Race

D1 START AND TIME LIMIT

- D1.1 It is the intention of the Race Committee to display course signals at 1055 and the warning signal at 1100.
- D1.2 The rendezvous location will be included in the Race Committee's announcement on VHF Channel 72 at 0900 in accordance with SI 3.5 and SI 6.
- D1.3 The Race Committee will use the VHF channel listed in SI 4.3.
- D1.4 The time limit is five hours.

D2 MARKS

D2.1 The starting mark will be an orange tetrahedron buoy. Mark "U", if used, will be a yellow tetrahedron buoy. The finishing mark will be a yellow tetrahedron buoy.

D2.2 The following are the designations for the rounding marks that might be used:

A	G "1B1" Fl G 4s Bell north of Block Island North Reef	(41° 15.481' N, 071° 34.544' W)
B	R "2" Fl R 4s Whistle approx. 3.2 nm south of Point Judith	(41° 18.462' N, 071° 28.348' W)
C	RW "NB" Mo (A) Whistle	(41° 23.009' N, 071° 23.357' W)
D	R "2" Q R Whistle Brenton Point	(41° 25.950' N, 071° 21.779' W)
E	GR "NR" Bell south of Beavertail Point	(41° 26.640' N, 071° 24.157' W)
F	R "6" Bell off Castle Hill	(41° 27.445' N, 071° 21.981' W)
G	RW "SR" Mo (A) Whistle	(41° 25.768' N, 071° 13.378' W)
H	Buzzards Light Tower Fl 2.5s 67ft 17M Horn	(41° 23.802' N, 071° 02.020' W)
W	G "3" Fl G 4s Whale Rock	(41° 26.663' N, 071° 25.227' W)

D2.3 G "9" Fl G 2.5s Gong off Bull Pt and G "11" Q G Bell off The Dumplings shall be passed on the channel side at all times.

D3 COURSES

Special courses will be designated using rounding marks as described in D2.2.

- a) The Race Committee will post the course on a white board on the starboard side of the Signal Boat, listing the marks in the order to be rounded, and the required side to leave each mark. The Race Committee will also announce the course on the fleet VHF channel. Failure to hear this announcement shall not be grounds for redress. This changes rule 62.1(a).
- b) Special Mark "U"
- The Race Committee may add a first mark to any course by posting mark "U".
 - The bearing and distance to Mark "U" will be displayed on a whiteboard and announced on the fleet VHF channel.
- c) The course will be:
- Start
 - Special Mark "U", if used
 - Round the marks in the designated order leaving each mark to the designated side
 - The finishing line will be off Fort Adams between a staff displaying an orange flag on a Race Committee Boat displaying a blue flag and the finishing mark, which will be a yellow tetrahedron buoy. The finishing line will be located approximately 0.25 NM north of the Fl R 6 sec Horn "2" on the northern point of Fort Adams.
- d) In fog at the finish, the Race Committee Boat may ring a bell rapidly, for approximately 5 seconds, at intervals. The same Race Committee Boat may or may not start and finish each race.

**NEW YORK YACHT CLUB
RACE WEEK AT NEWPORT**
Presented by Rolex

EVENT COMMITTEE

Chafee Emory, Chair
Jason Walsh, Chair

Robert C. Towse, Jr., Commodore, NYYC
Thomas J. Harrington, Vice Commodore, NYYC
A. Rives Potts, Jr., Rear Commodore, NYYC
Philip A. Lotz, Chairman, NYYC Sailing Committee

RACE COMMITTEE

Samuel W. Wakeman, Chair

BLUE

PRO Karin Olsen Nye
APRO Roger W. Fortier, Jr.
David K. Elwell, Jr.
Ingrid M. Flynn
Thomas K. Flynn
Peter A. Gerard
Bernadette Gotch
Lawrence Gotch
Ron Hopkins
Martin J. Kelly, MD
John Mendez
Pauline Mendez
Stephen R. Prime
Allegra M. Torrey
Samuel W. Wakeman

WHITE

Charles Henry Stuart
John L. Myles, Jr.
Robert Armes
David C. Brown, Capt, USN (Ret)
Richard R. Gumpert
Barbara Dixon Jackson
Daniel F. Jackson
Dorothy B. Myles
Ellyn C. Osmond
Eric P. Richards
Jill E. Urban

GREEN

A.R.G. Wallace, MD
Kevin Keogh
Elizabeth Isdale Cochran
Lyn Lowell Comfort
Margaret D. Comfort
Michael D. F. Deck, MD
Ingrid M. Flynn
Thomas K. Flynn
Timothy M. James
Barbara Anna Karpinska
Ellen I. Sykes
Joan Towse

Elizabeth Condon, Scorer
John I. Condon, Jr., Scorer
Rowena Dery, Scorer

PROTEST COMMITTEE

Timothea S. Larr, Chair
Carol Corbett Barrow
Peter A. Gerard
Richard R. Gumpert
Gregory R. Kiely
John D. Osmond III, MD
Charles Henry "Hank" Stuart
Richard V. Thursby
Catherine Kennedy - Secretary
Judy McLennan - Secretary
P.J. Thursby - Secretary